

BL'NDSPACE

SOLUTIONS TO CONCEAL BLINDS AND RECESS CURTAIN TRACKS

INTRODUCTION

WHAT WE DO

WE PROVIDE **ARCHITECTURAL SOLUTIONS**
DESIGNED **FOR BLINDS AND CURTAIN TRACKS**
TO DISAPPEAR INTO WALLS AND CEILINGS

SOLUTIONS FOR ANY TYPE OF WINDOW



WINDOWS & DOORS



CORNER WINDOWS



SHAPED WINDOWS



EAVES WINDOWS



SKYLIGHTS

BLINDS AND CURTAINS OUT OF SIGHT WHEN NOT REQUIRED

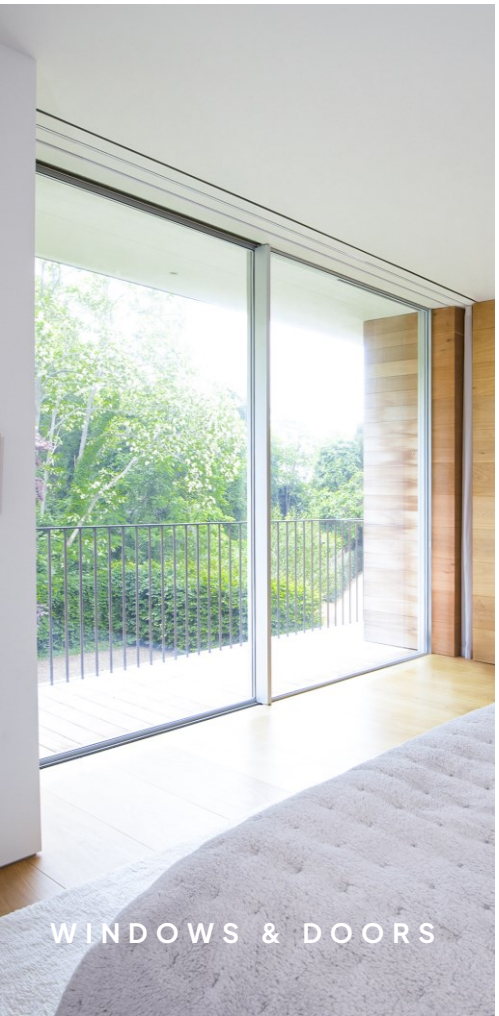

WINDOWS & DOORS



CORNER WINDOWS



SHAPED WINDOWS



EAVES WINDOWS



SKYLIGHTS

SERVING 200+ CLIENTS IN THREE SEGMENTS



PRODUCTION & DISTRIBUTION IN **THREE MARKETS**

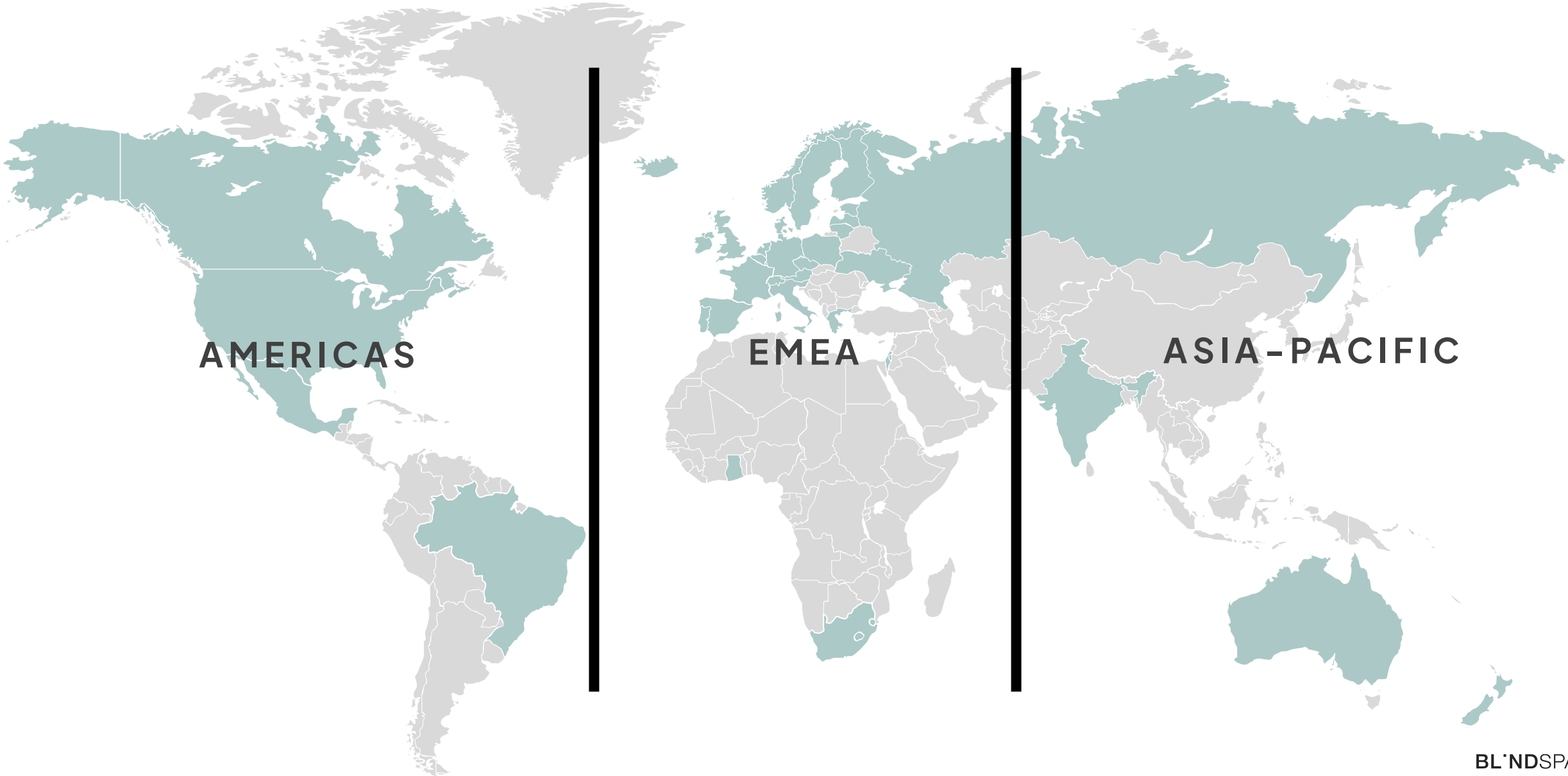

BL'NDSPACE
PRODUCTS

TRACKTRIM® - UNIQUE SOLUTIONS TO RECESS DRAPERY TRACKS

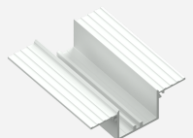
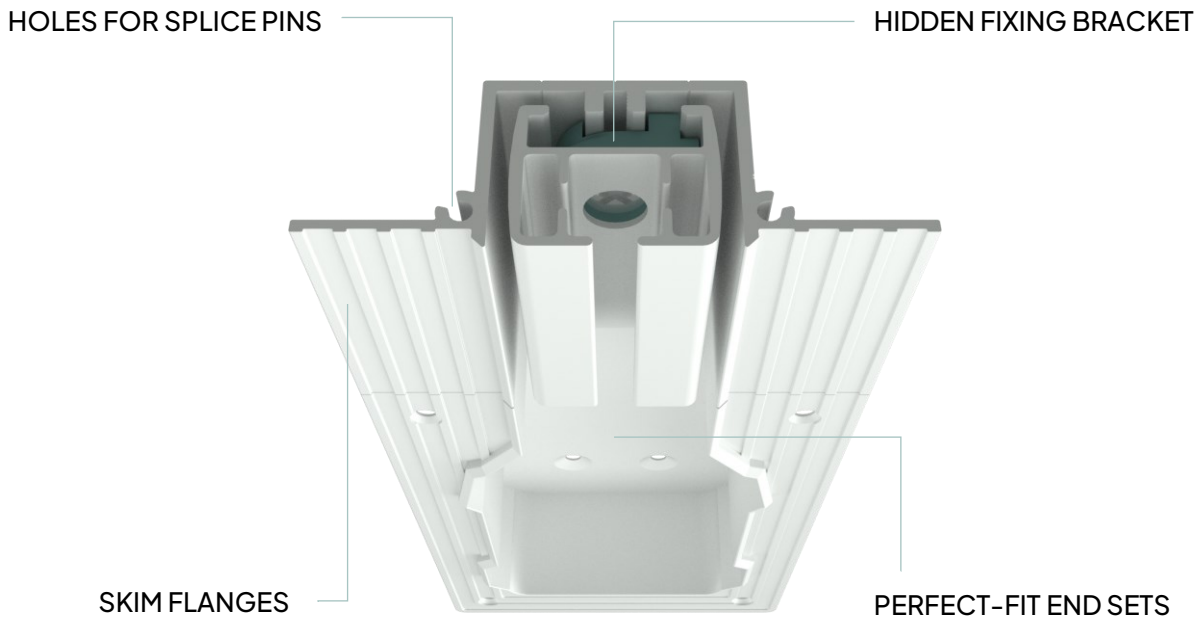

TRACKS



CURVED SECTIONS

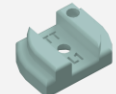

FIXING BRACKETS

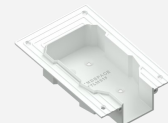

END SETS



SPLICE PINS

PERFECT-FIT END SETS FOR POPULAR **DRAPERY SYSTEMS**

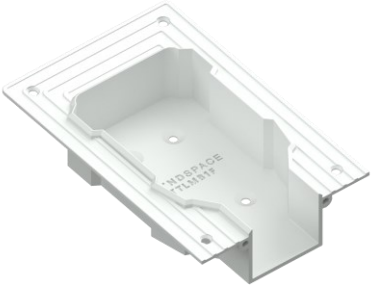

LUTRON

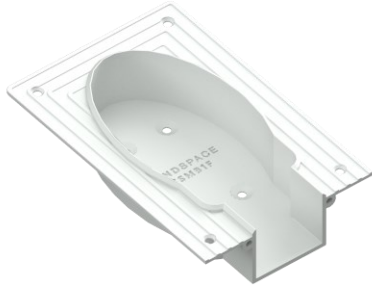

SOMFY



SILENT GLISS 5100



SILENT GLISS 5600

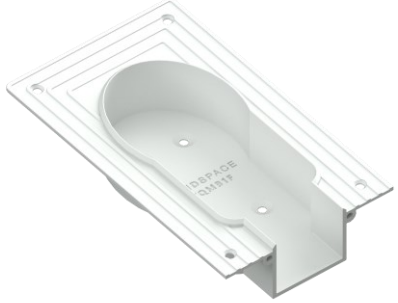

Q MOTION

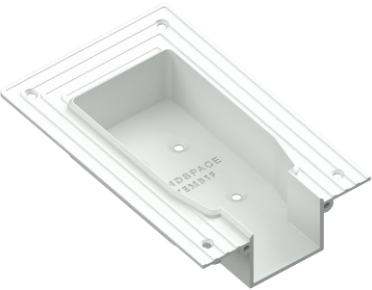

ERFAL

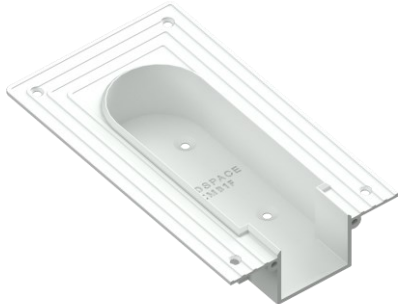

CRESTRON



COULISSE

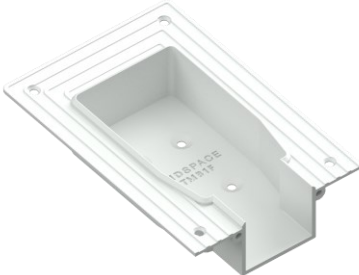

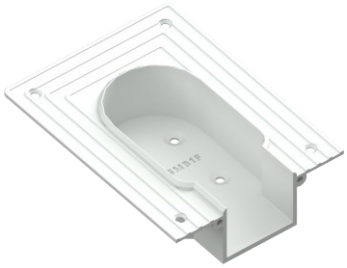

TRIETEX



GOELST

FEATURES & BENEFITS



FEATURES	BENEFITS
 Mud-in profiles to recess manual and electric drapery tracks	Tracks, curves and end sets all have skim coat flanges to minimize the risk of cracks.
 Brackets of different sizes and shapes to fit popular drapery tracks.	Brand specific brackets ensure flush installation of different drapery tracks.
 With or without a centered channel in the track profile, for fixing to.	Drapery tracks can be installed perfectly centered and fixed to the recessed profile.
 Perfect-fit end sets for Somfy, Lutron, Silent Gliss, Crestron and many more	Minimum ceiling cut-out with the recess perfectly following the shape of the ends.
 Flat ends for manual drapery tracks	Keep the same look in all windows with manual or electric drapery systems.
 Curved sections ranging from a radius of 250mm to 508mm.	Tracks can be installed in corner windows, bay windows and in other room layouts.
 Splice pins to connect track profiles, curve sections and end sets	Tracks can be delivered in shorter lengths and all parts perfectly align after installation.

BLINDSPACE® S SERIES STANDARD BOXES TO CONCEAL BLINDS IN WINDOWS AND DOORS

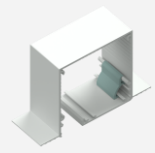
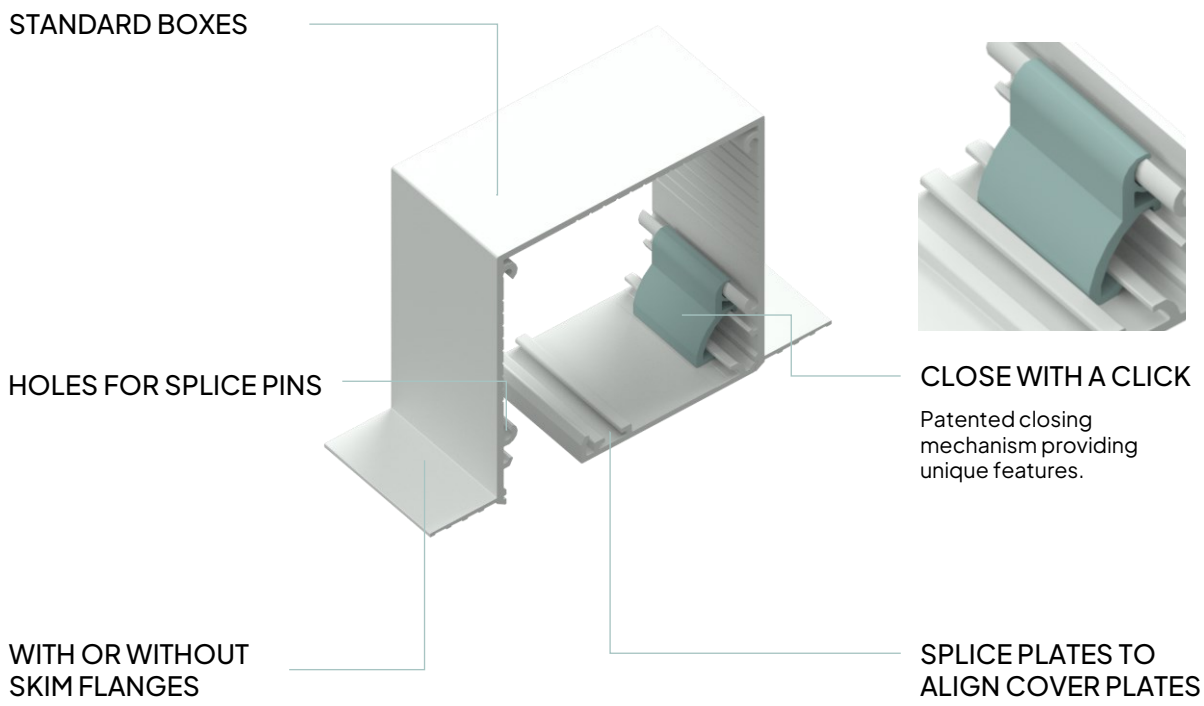

S100X100SS

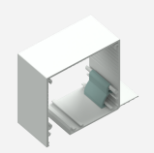

S100X100NS

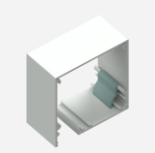

S100X100NN



S100X50SS

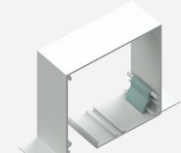

S130X130SS

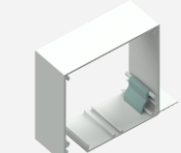

S130X130NS

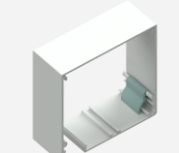



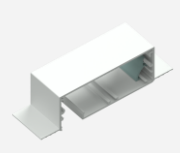



S130X130NN

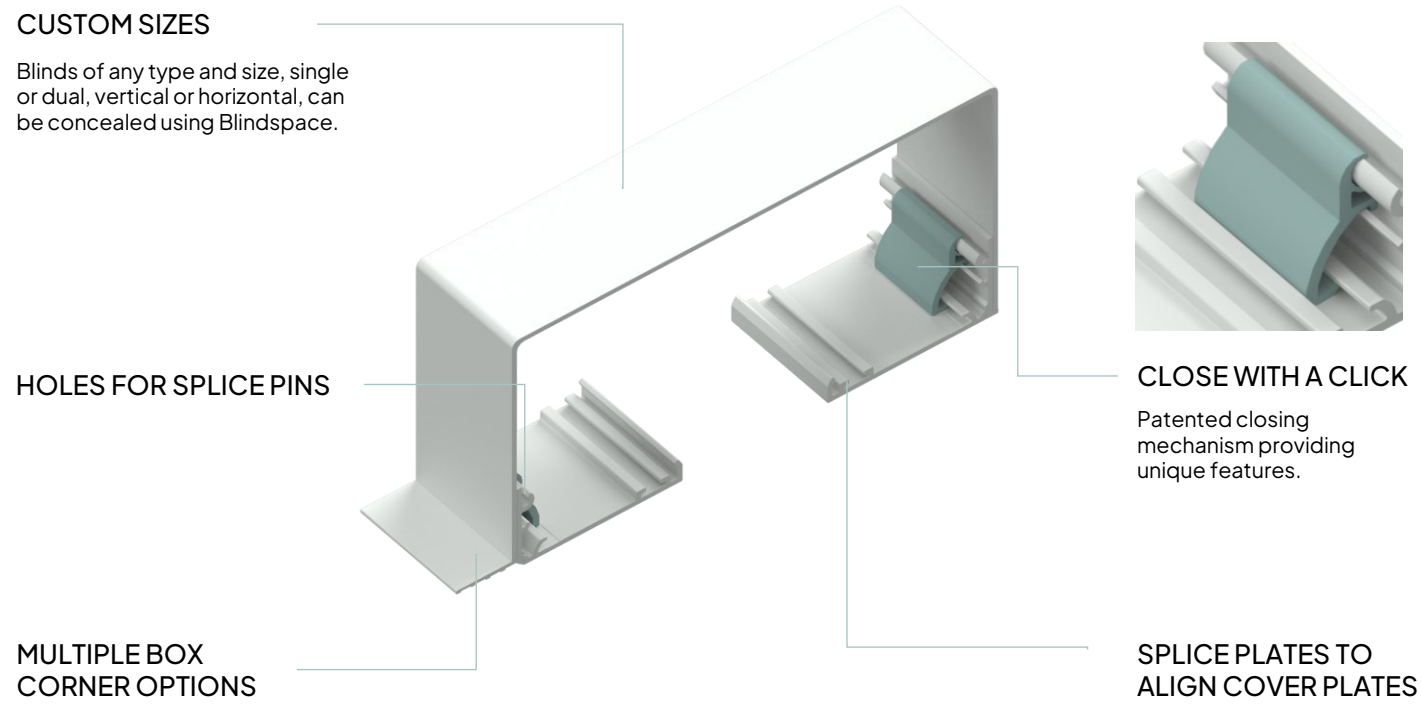

S130X50SS

BLINDSPACE® C SERIES TO CONCEAL ANY TYPE OF BLIND, IN ANY TYPE OF WINDOW



- 
NO FLANGE
- 
SKIM COAT FLANGE
- 
PERFORATED FLANGE
- 
VISIBLE FLANGE
- 
UPSTAND FLANGE

BLINDSPACE **PRODUCT SERIES**



S SERIES

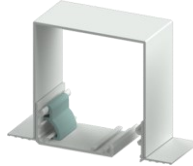

C SERIES



M SERIES









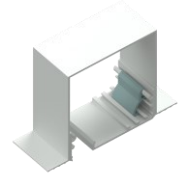



E SERIES

Type	Standard	Custom	Modular	Bespoke Extrusion
Key Features	High Volume Item White as default	Made to any measure Custom powder coated	Flexible configurations Black anodized back boxes	Designed to order for higher volumes
Sizes	100x100mm & 100x50mm 130x130mm & 130x50mm	Fabricated to measure Example sizes in price list	100 x 100mm & 100 x 70mm 130 x 130mm & 130 x 70mm	Extruded to measure
Lengths	Up to 6000mm	Up to 3000mm	Up to 5000mm	Up to 6000mm
Splicing	Pins for boxes Plates for covers	Pins for boxes Plates for covers	Pins for boxes Plates for covers	Based on design
End Caps	Flat end caps	Folded end caps	Flat end caps	Based on design

UNIQUE BOXES TO CONCEAL BLINDS IN ANY TYPE OF WINDOW



FEATURES	BENEFITS
 <p>Accessible space after construction is complete.</p>	<p>Concealed blinds can be installed and serviced at any time. No blinds involved during construction.</p>
 <p>Boxes available in standard and bespoke sizes.</p>	<p>Blinds of any type and size, single or dual, vertical or horizontal, can be concealed using Blindspace.</p>
 <p>Multiple box corner options available.</p>	<p>Boxes can be specified for any installation situation with no, plain, or skim coat flanges.</p>
 <p>Splice pins and splice plates to align boxes.</p>	<p>Two boxes and two covers can be spliced together for perfect alignment and end result.</p>
 <p>Covers available in standard and bespoke sizes.</p>	<p>The size of the opening gap can be designed to perfectly fit the blinds and bottom bar used.</p>
 <p>Covers can be made to fully close the box.</p>	<p>Windows can be prepared 'future-proofed' for potential future installation of concealed blinds.</p>
 <p>Covers shut with a click and stays in place.</p>	<p>Boxes can be installed in any direction for side channels, skylights or bottom-up blinds.</p>
 <p>Covers can be installed on either sides of the box.</p>	<p>Blinds can come out towards the window or towards the room, depending on preference.</p>
 <p>Covers are fixed with a safety hinge.</p>	<p>Cover can be opened and closed without the risk of the cover falling down from the ceiling.</p>
 <p>Powder coated to any colour or painted at site.</p>	<p>Boxes and covers can perfectly match the surrounding ceiling or wall.</p>

INSTALLED DURING CONSTRUCTION – **SPACE ACCESSIBLE WITH A CLICK**



WORKING WITH BL'NDSPACE

REASONS TO BECOME A CONCEALMENT EXPERT



- Door opener to get **more work from architects and designers**
- **Unique products enabling smarter concealment solutions** for any window
- **High value enquiries** and larger projects
- **Earlier involvement** securing the order also for shading products
- **New collaboration opportunities** with glazing companies

BLINDSPACE PARTNERSHIP STRUCTURE

DISTRIBUTOR

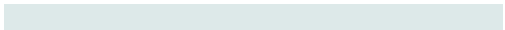

500-1000m price

Distributes to Blinds and AV companies. Set up with warehouse, cutting saws, packaging and Blindspace tape. Close collaboration and transparency with monthly reports.

STOCK CLIENT



100m price

Clients that stock products for their own projects. Stock clients often have a showroom installation and make their own off-cut samples to hand out to clients, architects and contractors.

PROJECT CLIENT



Trade price

From one-off clients to repeat clients with multiple projects every month. Repeat clients often have a showroom installation and uses samples in relation to specific projects.

KEY CLIENT



Trade price

Close collaboration, often with showroom installations featuring Blindspace products, handing out Blindspace samples and brochures, shared use of images and videos, promoting each other online including on social media.

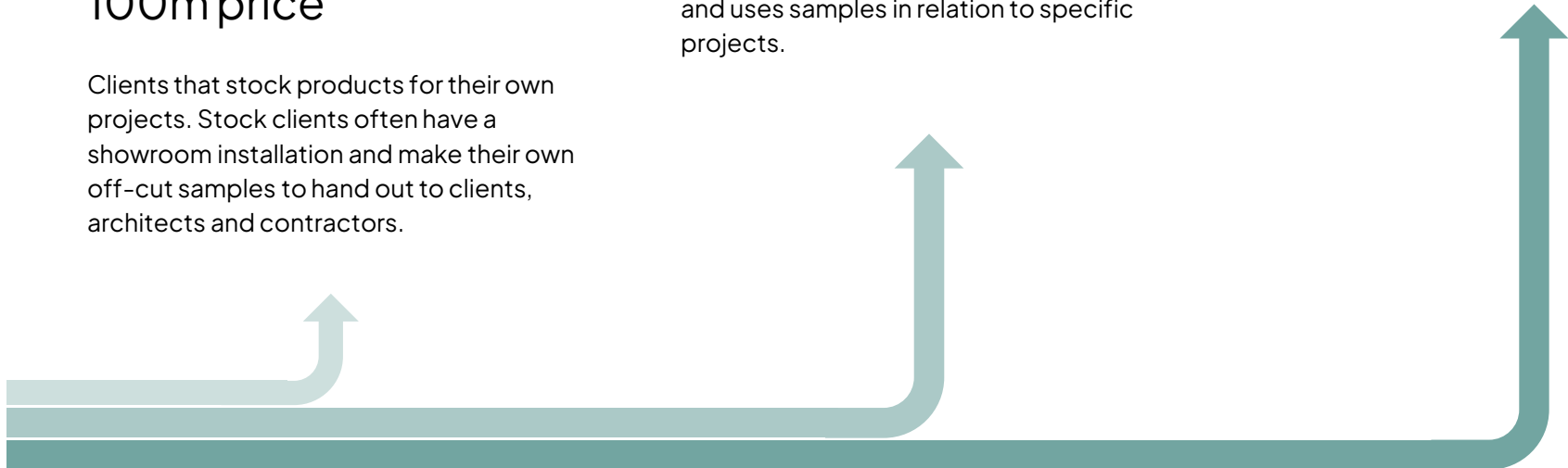

REASONS TO **BUY VOLUME AND HOLD STOCK**



Volume discounts on products and lower delivery costs



Shorter lead times and better service to customers



Opportunity to sell to other shading specialists and AV companies

WORDS FROM SOME OF OUR **DISTRIBUTORS**

We have worked closely with Blindspace, distributing products throughout the UK since 2018. It had been a steady growth and we supply between 100-150 companies with Blindspace products every year.



BILL WYATT
MANAGING DIRECTOR, FARNBOROUGH BLINDS
Distributor, United Kingdom

We are absolutely thrilled by the Blindspace opportunity. With many years in the industry we know good products when we see them and the architects and designers love them. We are sending products across Western Canada.



RHONDA HOLMAN
MANAGING DIRECTOR, HH POCKETS
Distributor, Canada

We represent Blindspace in Belgium, The Netherlands and Luxembourg and architects are really loving this solution. Also, the traditional decorators are seeing the positive effect of this solution and they have been presenting these solutions in their showrooms.



PHILIPPE BONNEEL
BUSINESS DEVELOPMENT, DECOLINE
Distributor, Belgium

We are distributors for Blindspace M SERIES in the US and it is a product like no other on the market. We have presented this at trade shows such as CEDIA with great results and are selling to AV dealers and shading specialists across the US.



HANNAH & BRIAN TONOALE
OWNERS, LIGHT & SHADE SOLUTIONS
Distributor, US

WORDS FROM SOME OF OUR OWNERS, PROJECT MANAGERS & TECHNICIANS

We are a traditional English shading company with long history working with brands such as Lutron and Silent Gliss. When looking at last years numbers, Blindspace was in 40% of our quotes going out. Amazing really!



STEVEN GOODE
MANAGING DIRECTOR, SHADING SPECIALISTS
Key Client, United Kingdom

As a specialist blinds installer, knowing that you have the space agreed available, the wiring in the right locations and able to quickly install and close the cover plates for millimeter precision, is price-less.



DAVE LACY
HEAD TECHNICAL ENGINEER, GRANTS BLINDS
Key Client, United Kingdom

We have grown the market for concealed blinds together with Blindspace with increasingly complex projects and installations. I am confident to say we are the most experienced Blindspace integrator in the world with more than 100 projects under our belt.



TONY EVANS
PROJECT MANAGER, GRANTS BLINDS
Key Client, United Kingdom

Join us!

We have established a global network of shading specialists and custom integrators that provide Blindspace products and services. Join our Team!

CONTACT US NOW

WE PROVIDE PRODUCT TRAINING, DRAWINGS, SALES MATERIAL, SUPPORT AND ENQUIRIES



Blindspace® S100x100SS
for Standard Roller Blind

HEAD BOX S100x100SS

SIDE BOX S100x100SS (OPTIONAL)

HEM BAR BOX S100x100SS (OPTIONAL)

1:2 scale

PRODUCT REFERENCE
S100x100SS
SERIES SIZE CORNERS

CONCEALMENT CONFIGURATION OPTIONS

BOX VARIATIONS

COVER HINGE
To hold cover plate, available on other side.

Product	Blindspace S100x100SS, S100x100SS
Description	Recessed box with optional flanges and hinged cover to conceal blinds flush with wall or ceiling finished surface.
Blind sizes	Please see size chart and supplier details for blind sizes such as max width, height and area.
Finishes	Provided in RAL 9016 (white) Optional powder coating to other RAL colours available.
Material	Powder Coated Aluminium, EN 6063 T6
Optional accessories	End cap Splice pin (to align boxes) Splice plate (to align covers) Chain guide (for manual blinds) Covers in various widths.
Box length	6000mm Cut to size for shorter lengths. Spliced together for longer lengths.
Installation	Boxes to be fixed with countersunk screws every 200mm through back (and both flanges when available) into appropriate backing. Screw tape to be used on flanges. Flushed cleat level to be flush with cover. Allow 3mm recess space for ease of installation, shown in dash line around boxes.
Print date	2022/10/10
Page size	ISO A3 420x297
Print file	Blindspace S100x100SS with standard color .jpg

BL'NDSPACE®

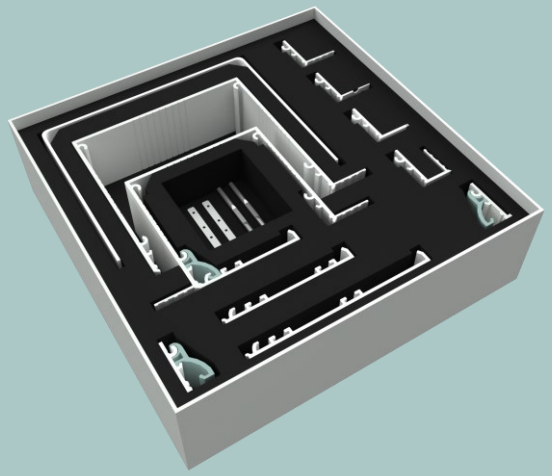

DRAWING TOOL

BL'NDSPACE MENU CONTACT | @ P

Technical Drawings

We provide drawings with recommended box sizes for generic products as well as for specific manufacturers. Please note that all blinds are not available in all markets, so please contact Blindspace or a local shading specialist to assist with your project. Please use the search bar and filters to find what you are looking for. This tool is new so please let us know your feedback.

Showing 270 of 270 items.

Sort By: All Measurements in Millimeters

Box Example Window Treatment max. max. Files

S100x100	↓	(Unbranded) Standard Roller Blind	Popular	2800	3000	📄
S100x100	↓	Lutron R64 - Roller Blind	Popular	2438	3000	📄
S130x130	↓	(Unbranded) Large Roller Blind	Popular	4000	4000	📄
S130x130	↓	SHY 85 ZIP 60/36 - Roller Blind with Zipped Side Channels	Popular	2500	2400	📄
C130x150	→	SHY 85 ZIP CTS 60/36 - Roof Roller Blind with Zipped Side Channels	Popular	2500	2485	📄
C155x250	→	Guthrie Douglas TESS 660L - Roof Tensioned Roller Blind with Zipped Side Chan...	Popular	3000	4500	📄
C89x89	↓	Lutron R64 - Roller Blind	Popular	2438	3000	📄
TT	→	TrackTrim to Recess Curtain Tracks From Lutron	Popular	9144		📄
TT	→	TrackTrim to Recess Curtain Tracks From Somfy Glydea Motor and Return Ends	Popular	14000		📄
S100x100	↓	(Unbranded) Future-proof Single Roller Blind		2800	3000	📄
S100x100	↓	Benthin RM06 - Roller Blind		2800	3000	📄
S100x100	↓	Benthin RM06 - Roller Blind with Side Guide Wires		2800	3000	📄
S100x100	↓	Benthin RS26 - Roller Blind		1800	2500	📄
S100x100	↓	Benthin RS26 - Roller Blind with Side Guide Wires		1800	2500	📄
S100x100	↓	Crestron ARCH3 - Roller Blind		2439		📄
S100x100	↓	Hunter Douglas EOS 37		2800	4000	📄
S100x100	↓	Hunter Douglas EOS 50		3500	4000	📄
S100x100	↓	Louvolite System 32® - Roller Blind		2000	5000	📄
S100x100	↓	Lutron R20 - Roller Blind		2438	2400	📄
S100x100	↓	Silent Gliss SG 4960 - Roller Blind		2400	4000	📄
S100x100	↓	Standard Roller Blinds in Corner - Butted Boxes with Room-Side Opening		2800	3000	📄



THE OPPORTUNITY

**BLINDSPACE PROVIDES A UNIQUE OPPORTUNITY
TO ESTABLISH YOUR COMPANY, AS THE GO-TO
FOR ARCHITECTS AND DESIGNERS.**

WE ARE LOOKING FOR LIKE-MINDED COMPANIES
THAT WANT TO PUSH THE BLINDSPACE BRAND IN
THEIR MARKETS AND CAN BRING VALUE TO IT.

FOR MORE **INSPIRATION**
AND UPDATES

blindspace.com

sales@blindspace.com

